

Letters to the Editor

THE MAGNETOELECTRIC EFFECT IN ANTIFERROMAGNETICS

D. N. ASTROV

Institute for Physico-Technical and Radio-Technical Measurements

Submitted to JETP editor December 28, 1959

J. Exptl. Theoret. Phys. (U.S.S.R.) **38**, 984-985 (March, 1960)

LANDAU and Lifshitz¹ showed the possibility of the existence of a linear relationship between the electric and magnetic field in a substance for certain types of magnetic crystal symmetry.

When a crystal of this type is placed in a magnetic (electric) field, an electric (magnetic) moment proportional to the field should appear. Dzyaloshinskii² showed that the magnetic symmetry group of Cr_2O_3 , whose magnetic structure is well known from neutron-diffraction measurements³ and from magnetic susceptibility data,⁴ admits of the existence of terms proportional to EH in the thermodynamic potential and, consequently, the magnetoelectric effect should occur in Cr_2O_3 .

Figure 1 is a schematic drawing of the device used to observe the magnetic moment appearing in a sample 1 of Cr_2O_3 when placed in an alternating electric field established by the electrodes 2. The signal from the astatic pair of measuring coils 3, which arises with the appearance of a mag-

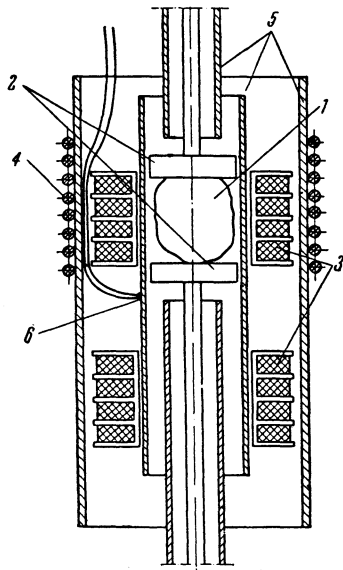

FIG. 1

netic moment, was fed to the input of a measuring amplifier through a balancing transformer. The noise level at the input of the amplifier did not exceed 10^{-7} v. The temperature was measured with a copper-constantan thermocouple 6 and could be controlled with the help of heater 4. Careful electrostatic shielding 5 was used. The measurements took place at a frequency of 10^4 cps. The effective value of the ac field was about 500 v/cm.

Figure 2 shows the temperature dependence of the signal at the output of the measurement amplifier for a field intensity of 430 v/cm (curve 1) and 230 v/cm (curve 2). The data was obtained

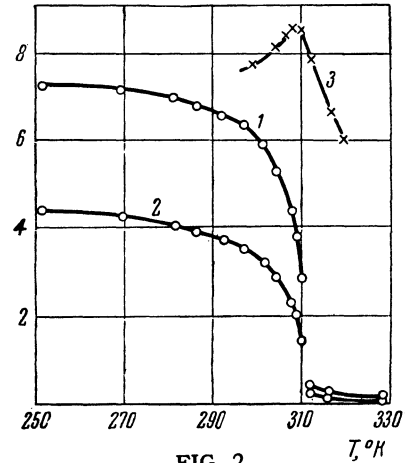

FIG. 2

with a single-crystal sample of Cr_2O_3 . The sample was kindly provided by the Institute of Physical Problems.* The sample was kept for about 10 minutes at the temperature corresponding to each point. The temperature of the antiferromagnetic transition was found to be 312°K .

The absence in the sample of ferromagnetic impurities, which could in the antiferromagnetic ordering lead to a temperature dependence of the measured signal similar to that described by curves 1 and 2, was checked by measuring the magnetic susceptibility of the sample at various temperatures near the transition point. The temperature dependence of the magnetic susceptibility (in relative units) is described by curve 3 and is of a form characteristic for an antiferromagnetic transition. The susceptibility was measured in the same device in an alternating magnetic field with an intensity of 6 oe and at a frequency of 10^4 cps, which was established by a solenoid mounted on the device.

Apparently, curves 1 and 2 should be considered as referring to the temperature dependence of the magnetic moment arising as a result of the magnetoelectric effect. The coefficient of proportionality α between the resultant magnetic moment

and the applied electric field which characterizes the extent of the effect (cf. reference 2) was estimated to be 1.2×10^{-5} at a temperature of 0°C .

The sample used had an irregular form and in estimating the coefficient α no correction for the demagnetizing factor was introduced. The large nonuniformity of the applied electric field was also not taken account of.

The author expresses his deep gratitude to Acad. P. L. Kapitza and I. E. Dzyaloshinskii for their interest in the work and for valuable advice, and also to A. S. Borovik-Romanov for a useful discussion of the results.

*The author expresses his gratitude to A. A. Popova of the Institute of Crystallography of the U.S.S.R. Academy of Sciences for growing the Cr_2O_3 single crystals.

¹L. D. Landau and E. M. Lifshitz, *электродинамика сплошных сред (Electrodynamics of Continuous Media)* Gostekhizdat, 1957.

²I. E. Dzyaloshinskii, JETP **37**, 881 (1959), Soviet Phys. JETP **10**, 628 (1960).

³B. N. Brockhouse, J. Chem. Phys. **21**, 961 (1953).

⁴McGuire, Scott, and Grannis, Phys. Rev. **98**, 1562 (1955).

Translated by Z. Barnea
185

ON THE MOMENTUM SPECTRUM OF π^+ MESONS FROM THE REACTION $\pi^+ + p \rightarrow 2\pi^+ + n$

V. A. ASTAF'EV

Institute of Nuclear Physics, Moscow State University

Submitted to JETP editor November 9, 1959

J. Exptl. Theoret. Phys. (U.S.S.R.) **38**, 985-987 (March, 1960)

IN the observation of the reaction $\pi^- + \pi^+ + \pi^- + n$ for an incident-meson energy $E_\pi = 1.37 \text{ Bev}^1$ in the laboratory system, the histogram representing the momentum spectrum of the π^+ and π^- meson was found to have two maxima: broad and low at small values of momentum and narrower and higher at large values of momentum. This was explained by Sternheimer and Lindenbaum² by means of the real isobaric nucleon model ($T = J$

$= 3/2$). It should be mentioned that, according to this model, a similar momentum spectrum should also be observed in the reactions $\pi^- + p \rightarrow \pi^- + \pi^0 + p$ and $\pi^+ + p \rightarrow 2\pi^+ + n$. The first of these reactions was studied in reference 1. The shape of the total momentum spectrum in this case is in better agreement with the statistical theory of Fermi, which gives one maximum at medium energies. Disparities with the conclusions of the isobaric theory are also mentioned in reference 3. In this connection, we should draw attention to the formal possibility, existing in theory, of not employing the notion of a real isobaric nucleon.

For simplicity, we consider the reaction $\pi^+ + p \rightarrow 2\pi^+ + n$, which occurs in the isotopic state with total angular momentum $T = 3/2$ and total meson angular momentum $\Lambda = 2$. We denote the momentum of the incident meson in the center-of-mass system by \mathbf{k}_0 and the momenta of the emitted mesons by \mathbf{k}_1 and \mathbf{k}_2 . As is known, this reaction is described by the matrix $\langle \mathbf{k}_1, \mathbf{k}_2 | T^{3/2;2} | \mathbf{k}_0 \rangle$, whose elements in the total angular momentum representation are $T_{J, l_1 l_2}^{3/2;2}(\mathbf{k}_1, \mathbf{k}_2, \mathbf{k}_0)$, where J is the total angular momentum, l is the orbital angular momentum of the incident meson, L is the total and l_1, l_2 the partial orbital angular momenta of the radiated mesons (see references 4 and 5); $L = l \pm 1$, $|l_1 - l_2| \leq L \leq l_1 + l_2$. The probability of observing a π^+ meson in a final state with a momentum of absolute magnitude k is given by the expression

$$\omega(k) = \frac{v}{2} \int_0^\pi \sin \theta d\theta \left\{ \left(\frac{d\sigma(k_1, k_2, \theta)}{dk_1} \right)_{k_1=k} + \left(\frac{d\sigma(k_1, k_2, \theta)}{dk_2} \right)_{k_2=k} \right\}, \quad (1)$$

where v is the velocity of the incident π meson, and θ the angle between the vectors \mathbf{k}_1 and \mathbf{k}_2 ; k_1 is determined from k_2 (and conversely) by the relativistic energy-momentum conservation law.

We shall be interested in the qualitative comparison of the spectra resulting from the individual partial states, i.e., $w_L(l_1 l_2)(k)$. We consider part of the matrix of the process under study $T' = \{A + B(\mathbf{k}_1 \mathbf{k}_0)^2\}(\sigma \mathbf{k}_0)$. Representing $(\mathbf{k}_1 \mathbf{k}_0)^2$ in an expansion in Legendre polynomials, we obtain

$$T' = \left\{ \left(A + \frac{1}{3} k_1^2 k_0^2 B \right) P_0(\cos \vartheta_{10}) + \frac{2}{3} k_1^2 k_0^2 B P_2(\cos \vartheta_{10}) \right\}(\sigma \mathbf{k}_0).$$

If the coefficient of P_2 is very much less than the coefficient of P_0 , then $T' \approx A(\sigma \mathbf{k}_0)$. Applying a similar argument to the matrix as a whole, we find that if

$$|T_{J, l_1 l_2}^{3/2;2}| \ll |T_{J, l_1 l_2}^{3/2;2}|$$