

Investigation of the Energy and Angle Distribution of Neutral Pions Produced by 470- and 660-Mev Protons in Carbon

IU. D. BAIUKOV, M. S. KOZODAEV AND A. A. TIAPKIN

Joint Institute for Nuclear Research

(Submitted to JETP editor October 28, 1956)

J. Exptl. Theoret. Phys. (U.S.S.R.) **32**, 667-677 (April, 1957)

Results of measurements of the energy spectra of γ -rays from the decay of neutral pions produced by 660-Mev protons in carbon are reported. The angle and energy distributions of the neutral pions obtained from an analysis of the spectra of γ -rays produced by 660- and 470-Mev protons in carbon are also given.

INTRODUCTION

BECAUSE neutral pions have a very short lifetime (5×10^{-15} sec) studies of the production processes and the interaction of these particles with nuclei are carried out by studying the hard γ -radiation which is produced in the decay of these mesons. From a measurement of the angle distribution of the γ -rays it is possible to determine the angle distribution of the neutral pions. Moreover, an investigation of the energy spectra of the γ -rays yields information both as to the energy as well as the angle distributions of the neutral pions which are produced.

The results of a study of the energy spectrum of γ -rays from the decay of neutral pions produced in Be and C targets by 470-Mev protons have been reported in Refs. 1 and 2. From an analysis of the spectra which were obtained the conclusion was

reached that the neutral mesons are produced with energies close to the maximum possible energy and with an angle distribution which is approximately proportional to $\cos^2 \theta$. Ref. 3 reported the results of a measurement of the spectra of γ -rays observed in the decay of neutral pions produced in a carbon target by 340-Mev protons. The authors of this work also concluded that the angle distribution of the neutral pions produced in complex nuclei is anisotropic.

In the present work* we report measurements of the energy spectra of γ -rays from the decay of neutral pions produced by 660-Mev protons in carbon nuclei and present an analysis of the spectra of the γ -rays. The data which were obtained are analyzed in conjunction with the results of similar measurements carried out earlier with 470-Mev protons.^{1,2}

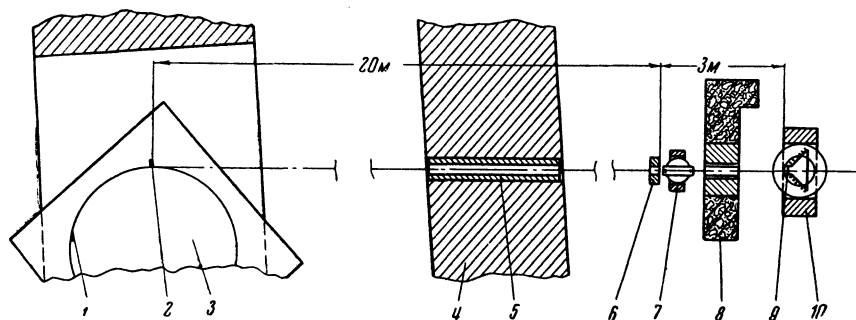

FIG. 1. Diagram of the experiment. 1) Proton trajectory, 2) target, 3) synchrocyclotron chamber, 4) concrete wall, 5) collimator, 6) diaphragm, 7) separation magnet, 8) supplementary shield, 9) converter of the spectrometer, 10) spectrometer.

EXPERIMENTAL ARRANGEMENT

Fig. 1 shows the experimental arrangement. The carbon target, located inside the vacuum chamber of the accelerator, is bombarded by protons with a

mean energy of 660 Mev. The γ -rays produced in the target pass through an aperture in a 4-meter concrete wall and are collimated by a diaphragm in

*The results of the present work have been presented at the CERN Symposium at Geneva in 1956.

a lead block. Charged particles are separated from the collimated beam of γ -rays by a magnetic field produced by a special electromagnet; the beam then strikes the converter of a 12-channel magnetic pair γ -spectrometer. The spectrometer is located 23 meters away from the target along a line tangent to the circular proton orbit.

The magnitude of the proton flux through the target is determined from the temperature difference at the ends of a copper rod which serves to support the target. The thermal conductivity of the rod is chosen so that the target temperature rises by several tens of degrees; hence, the heat loss by radiation is insignificant. In determining the proton flux, in addition to the target heating due to ionization loss, account is taken of heating due to star production.

PAIR γ -SPECTROMETER

The magnetic field in the spectrometer is produced by an electromagnet with a pole-piece diameter of 85 cm. The gap between the pole pieces is 6 cm. In studying γ -ray pole tips with an opening angle of 180° are used (Fig. 2a) are used to study γ -ray spectra in the energy range from 20 to 200 Mev because this arrangement yields semi-circular focusing of electrons and positrons is obtained and since wider and thicker converters can be used, it is possible to increase significantly the spectrometer efficiency. Pole tips with an opening angle of 90° (Fig. 2b) are used to measure spectra in the energy region from 100 to 450 Mev, and also γ -ray spectra at energies up to 600 Mev but in the latter case the unit containing the counters is placed at a greater distance from the converter.

Along the edges of the pole tips are placed two units with proportional counters which record electrons and positrons. Each unit contains a bank of six groups of coordinate counters and two banks of supplementary selection counters (Fig. 2). Each coordinate group, in turn, consists of three or four counters the center conductors of which are connected to the input of a single amplifier. The proportional counters used in the spectrometer are filled with pure methylal [$\text{CH}_2(\text{OCH}_3)_2$]. The cathodes of the counters are fabricated from thin-wall stainless steel tubing 10 mm in diameter.

After amplification and shaping, the pulses from each group of coordinate counters and from each bank of selection counters are fed to a coincidence circuit which produces a control pulse. The resolv-

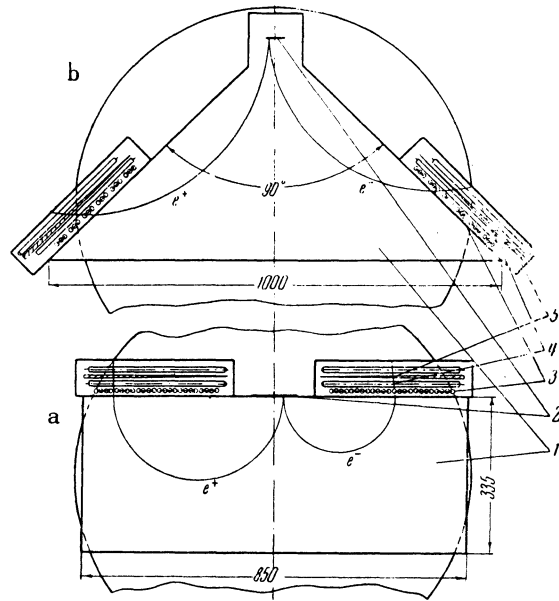

FIG. 2. Pole pieces and arrangement of the counters in the pair γ -spectrometer. 1) pole pieces, 2) converters, 3) coordinate counters, 4) selection counters, 5) filters.

ing time of the coincidence circuit is 5×10^{-7} sec. In addition to this coincidence circuit, the electronic system of the spectrometer contains a six-fold coincidence circuit which can be reduced to a five-fold coincidence circuit by disconnecting one of the banks of coordinate counters or selection counters. From the ratio of the counts in the main six-fold coincidence circuit to the counts in the five-fold coincidence circuit it is possible to determine the efficiency of the bank of counters which is disconnected.

The amplified pulses from the coordinate counters cause operation of the corresponding six-contact relay when the control signal is present. On closure of the contacts of the different pairs the relay operates one of eleven electro-mechanical registers, thus recording a γ -quantum of the appropriate energy. The number of γ -quanta detected by each group of coordinate counters is also determined by the corresponding electro-mechanical registers. The readings of these twelve counters are used for calculating the relative efficiency of the different coordinate counters and for the subsequent calculation of the relative average efficiency for detecting γ -rays in various energy ranges.

The resolving power of the spectrometer for each energy range, which is defined as the ratio of the average energy to the effective width of the energy interval, depends both on the geometry of the instrument as well as the thickness of the converter.

In our experiment rather thick copper converters were used (0.1, 0.3 and 0.5 mm respectively for measurements in the γ -ray energy regions 20–60, 50–200, and 200–600 Mev). The resolving power of the spectrometer for the sixth channel, determined mainly by the geometry of the device, is 13 with an opening angle $2\varphi = 180^\circ$ and 25 in the second case ($2\varphi = 90^\circ$).

Another important characteristic of the spectrometer is its efficiency, which is defined as the probability of detecting γ -rays which are incident on the converter. The efficiency of the spectrometer for a given energy range is given by the following expression:

$$\Phi = \kappa t_c \psi(\epsilon_\gamma, \Delta\epsilon_\gamma, \epsilon_e) \xi(\epsilon_\gamma, t_c) f_r.$$

Here, κ is the number of pair combinations of counters which record γ -rays of a given energy interval; $t_c \psi(\epsilon_\gamma, \Delta\epsilon_\gamma, \epsilon_e)$ is the probability for the production in the converter of thickness t_c of an electron-positron pair with energy sufficient for detection by the spectrometer counters; $\xi(\epsilon_\gamma, t_c)$ is a factor which takes into account the reduction in spectrometer efficiency due to scattering of electrons and positrons in the converter and f_r is the efficiency of the counters in the spectrometer measured by disconnecting various series of counters successively.

RESULTS OF THE MEASUREMENTS

The energy spectra of γ -rays from the decay of neutral pions produced by 660-Mev protons in carbon have been measured at angles of 0° and 180° with respect to the bombarding proton beam. In the spectrum measurements at 0° approximately 6×10^4 electron-positron pairs were recorded. The spectrum at 180° has been plotted on the basis of a measurement of the energies of 4×10^4 pairs. In each separate run, at a fixed intensity of magnetic field, measurements were made of a section of the γ -ray spectrum at eleven different energy intervals. The intensity of the magnetic field in the individual measurements was chosen in such a way that each section of the spectrum was measured in two runs by different energy channels of the spectrometer. This procedure made it possible to normalize the separate measurements in overlapping sections of the spectrum. The normalizing factors determined in this fashion were found to be in agreement, within the error limits, with the ratios of spectrometer efficiencies calculated for the corresponding magnetic-field intensity.

Fig. 3 shows the results of a measurement of the

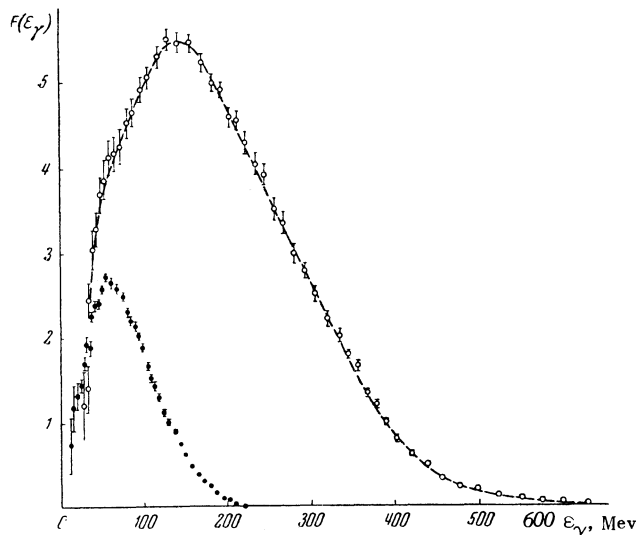

FIG. 3. Energy spectrum of γ -rays from the decay of neutral pions produced by 660-Mev protons in carbon. (O) angle of observation 0° ; (●) angle of observation 180° .

γ -spectra at angles of 0° and 180° , obtained by averaging the results of individual measurements, taken with weighting factors proportional to their statistical accuracy.

In the laboratory coordinate system the differential cross-section for the production of γ -quanta in carbon by 660 Mev protons at an angle of 180° is

$$d\sigma_C^\gamma/d\omega(180^\circ) = (1,5 \pm 0,2) \cdot 10^{-27} \text{ cm}^2/\text{sterad},$$

which is in agreement with the data of Ref. 4. The ratio of the total flux of γ -rays at 0° and 180° is 5.1 ± 0.3 .

ANALYSIS OF THE γ -RAY ENERGY SPECTRA

1. *Dependence of the energy spectrum of γ -rays from carbon on the angle and energy distributions of the neutral pions.* The energy spectrum of the γ -rays $F(\epsilon_\gamma)$ at angles of 0° and 180° in the center of mass system (CMS) of the colliding nucleons is related to the function $\psi(\epsilon_\pi, \theta)$, which determines the energy and angle distributions of the neutral pions, by the following expression:

$$F(\epsilon_\gamma) = \int_{\epsilon_\pi^*}^{\infty} \frac{\psi(\epsilon_\pi, \theta)}{\sqrt{\epsilon_\pi^2 - \epsilon_0^2}} d\epsilon_\pi. \quad (1)$$

Here the lower integration limit $\epsilon_\pi^* = \epsilon_\gamma + (\epsilon_0^2/4\epsilon_r)$ is the rest energy of the neutral pion and $\theta = \arccos \{ [\epsilon_\pi - (\epsilon_0^2/2\epsilon_\gamma)] / \sqrt{\epsilon_\pi^2 - \epsilon_0^2} \}$ is the

angle between the direction of motion of the neutral pion and the detected γ -quantum.

In the production of neutral pions in complex nuclei, because of internal motion of the nucleons, there is no single CMS for the colliding neutrons. However, it is possible to make use of an effective CMS, which is found in the impulse approximation from a calculation of the energy dependence of the meson-production cross section. Since the momentum of the proton which bombards the nucleus is considerably greater than the momenta of the nucleons inside the nucleus, we may use the expression given in Eq. (1) for analyzing the spectra of γ -rays converted to an averaged coordinate system. Furthermore, in analyzing the spectra we will take account of the angle and energy distributions independently, that is, we assume

$$\psi(\varepsilon_\pi, \theta) = f(\varepsilon_\pi) \varphi(\theta),$$

where $f(\varepsilon_\pi)$ and $\varphi(\theta)$ are the energy spectrum and angle distribution of the neutral pions.

From Eq. (1) it is apparent that for an isotropic neutral-pion distribution, regardless of the energy distribution, the γ -ray spectrum plotted on a graph with a logarithmic scale along the abscissa axis should be symmetric with respect to the energy $\frac{1}{2}\varepsilon_0$. The presence of anisotropic effects in the pion angle distribution disturbs the logarithmic symmetry of the spectrum. Thus, with an angle distribution proportional to $\cos^2\theta$ the maximum of the spectrum is displaced toward higher energies.

If the function $\psi(\varepsilon_\pi, \theta)$ in Eq. (1) can be given in the form of a product of the functions $f(\varepsilon_\pi)$ and $\varphi(\theta)$ (the energy and angle distributions of the neutral pions in the CMS of the colliding nucleons respectively), we obtain upon differentiation of Eq. (1) with respect to ε_γ the following expression for the pion energy distribution:

$$f(\varepsilon_\pi^*) = - \frac{\varepsilon_\gamma}{\varphi(\theta)} \frac{dF(\varepsilon_\gamma)}{d\varepsilon_\gamma} - \frac{\varepsilon_\gamma}{\varphi(\theta)} \int_{\varepsilon_\pi}^{\infty} \frac{f(\varepsilon_\pi)}{\sqrt{\varepsilon_\pi^2 - \varepsilon_0^2}} \frac{d\varphi}{d\theta'} \frac{d\theta'}{d\varepsilon_\gamma} d\varepsilon_\pi. \quad (2)$$

For an isotropic angle distribution $\varphi(\theta) = \text{const.}$ the second term in Eq. (2) vanishes. In this case the neutral pion spectrum is determined from the simple relation

$$f(\varepsilon_\pi^*) = - \varepsilon_\gamma dF(\varepsilon_\gamma) / d\varepsilon_\gamma.$$

The meson energy distribution $f(\varepsilon_\pi^*)$ can be found independently by using the section of the energy spectrum $F(\varepsilon_\gamma)$ located in the γ -ray energy region $\varepsilon_\gamma \geq \frac{1}{2}\varepsilon_0$ as well as the section in which $\varepsilon_\gamma \leq \frac{1}{2}\varepsilon_0$. In the general case, to determine the energy spectrum of the neutral pions it is necessary to know the angle distribution $\varphi(\theta)$. However, examination of Eq. (2) indicates that if the function $f(\varepsilon_\pi^*)$ is determined from the hard part of the spectrum $F(\varepsilon_\gamma)$, the second term in the right-hand part yields only a small correction to the first term even for an angle distribution which is given by the expression $\varphi(\theta) = \cos^2\theta$. This is due to the fact that the hard part of the spectrum is determined basically by the energy spectrum of neutral pions which move in the direction of the spectrometer and is only slightly dependent on the angle distribution if it is given by an expression of the form $\varphi(\theta) = a + b \cos^2\theta$ (for $a > 0$ and $b > 0$). In the case of the angle distribution indicated above, the ratio between the constants a and b is important for the spectrum $F(\varepsilon_\gamma)$ only in the energy region $\varepsilon_\gamma < 150$ Mev in the CMS of the nucleons.

The energy spectrum of the neutral pions $f(\varepsilon_\pi)$ is found in first approximation by solving the integral equation (2) in the hard region of the spectrum $F(\varepsilon_\gamma)$ by a method of successive extrapolation from high values of ε_π to smaller values, using the approximate expression for $\varphi(\theta)$ in the angle distribution. Using the neutral meson spectrum found in this way it is possible to find a more exact expression for the angle distribution function $\varphi(\theta)$ by comparing, in the lower energy region, the experimental γ -ray spectrum with the spectra calculated for various values of the constants a and b . In turn, using the more accurate angle distribution it is possible to find a more accurate spectrum $f(\varepsilon_\pi)$. However, this determination of the angle distribution of neutral pions is possible only if the energy spectrum of the neutral pions in the CMS is weakly dependent on the meson emission angle.

2. *Comparison of the energy spectra for γ -rays from the decay of neutral pions produced by 470 and 660 Mev protons.* The γ -ray spectra obtained by bombarding a carbon target with 660-Mev protons (Fig. 3) differs considerably from the spectrum measured at a proton energy of 470 Mev (Figs. 4, 5 and Ref. 2). As the proton energy is changed from 470 to 669 Mev the upper limit of the spectrum increases in correspondence with the increased maximum collision energy

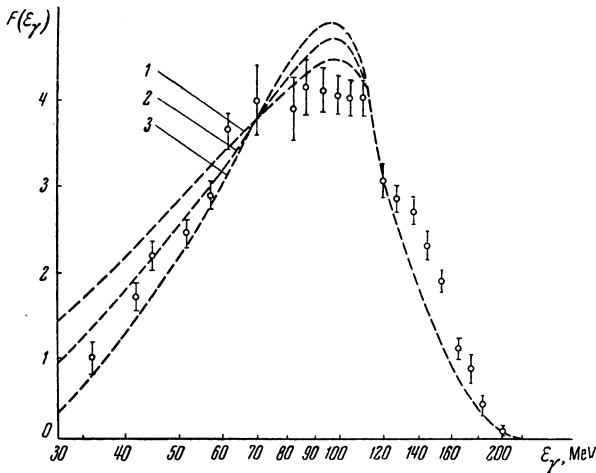

FIG. 4. Energy spectrum of γ -rays from the decay of neutral pions produced by 470-Mev protons in beryllium. Angle of observation 180° . \circ) measured spectrum. The dashes indicate the spectra computed under different assumptions as to the value of the constant a in the angle distribution $\varphi(\theta) = a + \cos^2 \theta$: 1) $a = 0.3$; 2) $a = 0.15$; 3) $a = 0$.

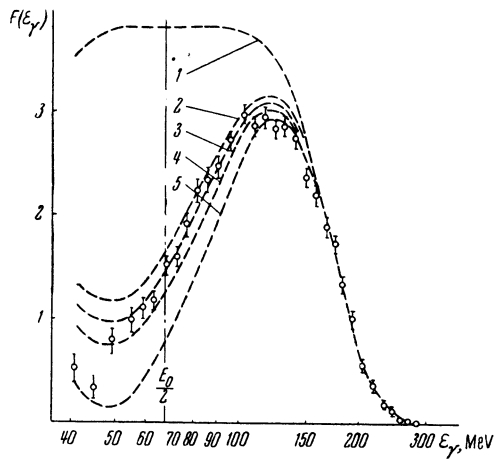

FIG. 5. Energy spectrum of γ -rays from the decay of neutral pions produced by 470-Mev protons in carbon in the CMS. Angle of observation 0° . \circ) measured spectrum. The dashes indicate the spectra computed under various assumptions as to the magnitude of the constant a in the angle distribution $\varphi(\theta) = a + \cos^2 \theta$: 1) isotropic; 2) $a = 0.4$; 3) $a = 0.3$; 4) $a = 0.2$; 5) $a = 0$.

of the proton and the nucleon in the nucleus. At the same time the mean energy of the γ -rays does not increase but, indeed, is found to be smaller: this energy is 190 Mev at $E_p = 470$ Mev and 170 Mev at $E_p = 660$ Mev for spectra measured at an angle of 0° with respect to the proton flux. This fact means that there is a change in the character of the energy and angle distributions of the neutral pions which are produced.

The form of the γ -ray spectra measured at a proton energy of 470 Mev indicates that the neutral-pion angle distribution contains a term proportional to $\cos^2 \theta$. The γ -ray spectrum measured at an angle of 0° at $E_p = 660$ Mev has greater logarithmic symmetry (Figs. 5 and 6). This would seem to indicate that the angle distribution for neutral pions produced by 660-Mev protons is more isotropic.

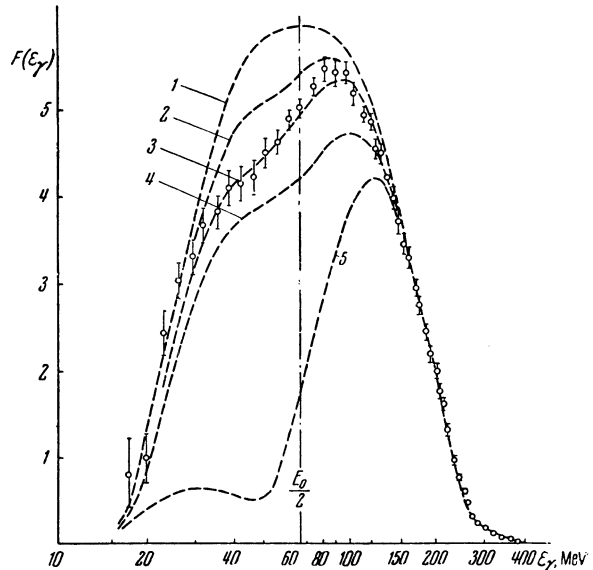

FIG. 6. Energy spectrum of γ -rays from the decay of neutral pions produced by 660-Mev protons in carbon in the CMS. Angle of observation 0° . The dashes indicate the spectra computed under various assumptions as to the magnitude of the constant b in the angle distribution $\varphi(\theta) = 1 + b \cos^2 \theta$: 1) $b = 0$; 2) $b = 0.2$; 3) $b = 0.4$; 4) $b = 0.6$; 5) $\varphi(\theta) \sim \cos^2 \theta$.

A comparison of the γ -ray spectra also indicates that there is an essential change in the nature of the energy spectra of the neutral pions as the proton energy is increased from 470 to 660 Mev. At proton energies of 470 Mev the neutral pions are produced with energies close to the maximum possible energy which the meson can acquire in the reaction. This conclusion is drawn on the basis of a comparison of the measured γ -ray spectra with the spectra calculated in the impulse approximation from the dependence of the pion production cross section on the collision energy of the nucleons under the assumption that the meson acquires the maximum possible energy. A comparison of the spectra calculated with various assumptions as to the magnitude of the constant a in the angle distribution $\varphi(\theta) = a + \cos^2 \theta$ with the spectrum for γ -rays measured at 180° with respect to the proton flux (Be target) is given in Fig. 4. From a

comparison of the calculated spectra and the experimental spectrum it is possible to make an estimate of the constant a in the angle distribution of the neutral pions which are produced:

$$a = 0,15 \pm 0,15.$$

A comparison of the γ -ray spectra calculated under the assumptions given above with the experimentally-determined spectra at proton energies of 660 Mev indicates a considerable difference. Regardless of the magnitude of the constant a in the pion angle distribution the calculated γ -ray spectra are found to be considerably harder than the spectrum measured at an angle of 0° . It follows from this fact that at proton energies of 660 Mev the neutral pions are produced mainly with energies considerably below the maximum possible energy. This conclusion has also been reached on the basis of an analysis of the γ -ray spectrum measured at 180° ⁵ and the mean energies of γ -quanta at angles of 0° and 180° as measured by an absorption method.⁴

3. *Energy spectra of neutral pions produced by 470 and 660 Mev protons.* Fig. 7 shows the pion energy distributions in the effective CMS for meson production in carbon by 470 Mev protons. These distributions have been calculated from the hard portion of the spectrum measured at 0° assuming an isotropic pion angle distribution and a distribution proportional to $\cos^2 \theta$. In this same figure the dashed curve indicates the pion spectrum calculated in the impulse approximation under the assumption that the mesons which are produced always acquire the maximum possible energy. The calculation was carried out under the assumption that the momentum distribution of nucleons in the nucleus is given by a Gaussian function with a mean-square momentum of 120 Mev/c. Comparison of the pion spectrum (Curve 1) with the spectrum calculated as indicated above (dashed curve) shows that when the carbon target is bombarded by 470-Mev protons the mesons are produced with energies close to the maximum possible energy. The difference between these curves is actually smaller if account is taken of the proton energy loss due to passage through the carbon nucleus. The hard part of the spectrum $F(\epsilon_\gamma)$ contains γ -quanta due to the decay of neutral ions which enter the spectrometer. Considering the strong absorption of neutral pions in nuclear matter^{4,2} it may be assumed that the γ -quanta recorded by the spectrometer (hard part of

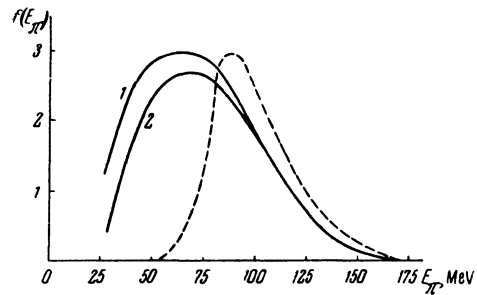

FIG. 7. Energy spectrum of neutral pions produced by 470-Mev protons in carbon in the CMS. The solid curves are the spectra computed for the hard part of the measured spectrum under the following assumptions: 1) isotropic distribution, 2) distribution proportional to $\cos^2 \theta$.

the spectrum) appear as a result of the decay of neutral pions which are formed at the surface of the nucleus facing the observer. In measurements of the γ -ray spectra at an angle of 0° the surface of the nucleus facing the observer is bombarded by protons which have first passed through the nucleus. In this case the proton flux becomes energetically less homogeneous and the average particle energy is reduced. This effect has not been taken into account in calculating the spectrum shown by the dashed curve. A considerably smaller difference is observed between the spectra measured at 180° and the spectrum calculated in the impulse approximation (cf. Fig. 4). However, in this case the energy spectrum of the γ -quanta may be distorted in the hard portion because of scattering of neutral pions in the same nucleus in which they are produced.

Fig. 8 shows the pion energy spectrum in the CMS for proton energies of 660 Mev. The spectrum was

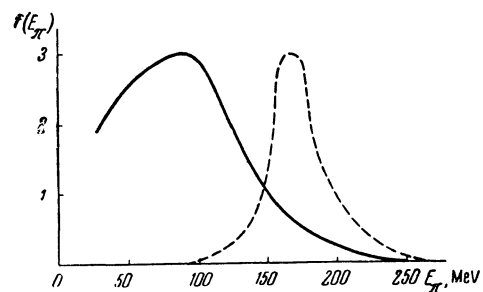

FIG. 8. Energy spectrum of neutral pions produced by 660-Mev protons in carbon in the CMS. The dashed curve is the spectrum calculated in the impulse approximation.

calculated under the assumption of an isotropic pion distribution in the hard part ($\epsilon_\gamma > \frac{1}{2}\epsilon_0$) of the γ -ray spectrum measured at an angle of 0° represented by the smooth curve (cf. Fig. 3). The dashed curve denoted the pion spectrum computed in the impulse

approximation; the calculation was carried out under the assumption that the produced mesons acquire the maximum possible energy.

4. *Angle distributions for neutral pions produced by 470 and 660 Mev protons.* In the energy region $\epsilon_\gamma \leq \frac{1}{2}\epsilon_0$ the shape of the γ -ray spectrum depends strongly on the pion angle distribution. This fact can be utilized to obtain a more accurate determination of the angle distribution by a comparison of the measured γ -ray spectrum with the spectra calculated in accordance with different assumptions to the angle distribution. The calculation of the spectra is carried out using the neutral-pion energy distribution found earlier from the hard part of the measured γ -ray spectrum.

From a comparison of the computed and measured γ -ray spectra at proton energies of 470 Mev and an angle of observation of 0° (cf. Fig. 5) it is apparent that the best agreement is found for the angle distribution $\varphi(\theta) = 0.3 + \cos^2 \theta$. Taking into account the uncertainty in the measured spectrum, it may be assumed in agreement with the data of Ref. 6. that the constant $a = 0.3 \pm 0.1$. The less accurate determination of this constant presented above, using the γ -ray spectrum measured at 180° , yields $a = 0.15 \pm 0.5$. The values of the constant are in agreement within the error limits. A comparison of the computed γ -ray spectra with that measured at an angle of 0° for a proton energy of 660 Mev (Fig. 6) indicates that satisfactory agreement obtains for an angle distribution $\varphi(\theta) = 1 + 0.4 \cos^2 \theta$. Taking account of the errors in the measurement of the γ -ray spectrum it may be assumed that the constant $b = 0.4 \pm 0.2$.

The angle distributions $\varphi(\theta)$ which have been obtained can, in turn, be used to calculate a more exact spectrum of the neutral pions. However, this correction to the neutral pion spectra is considerably smaller than the uncertainty in the spectra which arise as a result of the simplifying assumptions which have been used in the analysis and the errors in the measurements of the γ -ray spectra which are being analyzed.

It has already been noted above that the use of this method of analysis of γ -ray spectra can give only approximate information on the angle and energy distributions of neutral pions produced in complex nuclei. It should be pointed out that in addition to the approximations which have been indicated earlier, which are valid for this analysis, there is still one more source of uncertainty in the determination of the angle distributions and the

spectra of the neutral pions. The additional errors in the analysis are due to changes in the meson energy and angle distributions due to the particular opacity of the nucleus to the bombarding protons and also due to the interaction of mesons with nucleus in which they are produced. It has been shown in Ref. 4 that even for light nuclei (Li and C) these effects can cause a considerable change in the γ -ray angle distribution. This finding is also corroborated by the change in the ratio of the γ -ray flux observed in the present work at angles of 0° and 180° . As has already been remarked, this ratio, measured in carbon with the γ -spectrometer, was found to be 5.1 ± 0.3 . Measurements with a scintillation-counter telescope and a Cerenkov counter show this ratio to be 5.5 ± 0.1 .⁷ However, for a pion angle distribution which is symmetric in the CMS with respect to the motion of the colliding nucleons, this ratio should be 9.6 in the case in which meson production occurs in nucleons at rest, and 8–9 in the case of meson production in nucleons moving inside the nucleus. In the determination of the pion angle distribution from the γ -ray spectrum measured at an angle of 0° with respect to the motion of the protons which bombard the target, the indicated effects lead to a value which is too high for the constant a as found by the method described above.

DISCUSSION OF THE RESULTS

From an investigation of the energy spectra and the angle distributions for neutral pions produced in the bombardment of complex nuclei by protons it is possible to draw certain conclusions as to the nature of the pion production process in nucleon collisions.

The energy and angle distributions for neutral pions found from the γ -ray spectrum measured at a proton energy of 470 Mev indicate that in this case the neutral mesons produced in the nucleon collision acquire a large part of the free collision energy and also a large angular momentum, and, consequently are produced for the most part in P -states. This same pattern has been observed at lower proton energies as indicated on the basis of the γ -ray spectra measured in Ref. 3. At proton energies of 470 Mev the neutral pions are produced mainly in $(p-n)$ collisions since the cross-section $\sigma_{pp}^{\pi^0}$ is approximately four times smaller than $\sigma_{pn}^{\pi^0}$.⁶ Hence the conclusion which has been indicated pertains to the production

of neutral pions in the collision of protons with neutrons in the nucleus. Using this same ratio for the cross-sections $\sigma_{pn}^{\pi^0}/\sigma_{pp}^{\pi^0} = 4$ the neutral pions produced in p - p collisions can have an important effect on the magnitude of the constant a in the angle distribution for mesons produced in complex nuclei if the angle distribution for the reaction $p + p \rightarrow \pi^0 + p + p$ is almost isotropic. However, according to the data of Ref. 7, the angle distribution for neutral pions in the latter reaction for a proton energy $E_p = 470$ Mev within the limits of the experimental error, does not differ from the meson angle distribution $\varphi(\theta) = (0.3 \pm 0.1) + \cos^2 \theta$ in production in complex nuclei. Hence, it may be assumed that the angle distribution for neutral pions produced in collisions of protons with neutrons in the nucleus does not differ considerably from the obtained distribution $\varphi(\theta) = 0.3 + \cos^2 \theta$.

Investigations of the reaction $n + p \rightarrow \pi^0 + d$ at a neutron energy $E_n = 400$ Mev carried out by Hildebrand⁸ and Schuler⁹ show that the meson angle distribution in this case is given by a function of the form $\varphi(\theta) = a + \cos^2 \theta$ with the constant $a = 0.21 \pm 0.6$ [sic!] according to the data of the first reference and $a = 0.28 \pm 0.26$ according to the data of the second reference. The fact that the neutral-pion angle distribution, for pions produced in collisions of protons with neutrons in the nucleus, does not differ, within the experimental errors, from the angle distribution in the reaction $n + p \rightarrow \pi^0 + d$ may indicate that in the production of mesons in complex nuclei in p - n collisions there is a strong interaction between the final nucleons in the S -state.

This conclusion follows more directly from the fact that the neutral pions which are produced acquire a large part of the free energy of the reaction. A similar pattern has also been observed in reactions which involve the production of charged pions.¹⁰

In Ref. 4 mention was also made of the change in the nature of the pion production process found with an increase of proton energy from (340–470) to 670 Mev. An examination of the angle and energy distributions obtained in this work leads to the same conclusion. While the spectrum for neutral pions produced in complex nuclei at a proton energy of 470 Mev is not greatly different from the spectrum computed a maximum possible energy, at a

proton energy of 660 Mev there is a considerable difference between the observed spectrum and the spectrum computed according to this same assumption. At a proton energy of 660 Mev in the great majority of cases the pions are produced with energies considerably below the maximum possible energy. It follows from this situation that in the production of neutral pions by 660 Mev protons the nucleons in the final state possess a large kinetic energy and, consequently, a high momentum. However, this is possible only if the nucleons are emitted at large angles with respect to each other, consequently, in the final state of the reaction the nucleons interact in states with high angular momentum (in the P -, D -, ... states).

As the proton energy is increased from 470 to 660 Mev the pion angle distribution changes considerably. At a proton energy of 470 Mev the ratio of the number of pions, distributed isotropically in the CMS of the colliding nucleons to those distributed according to a $\cos^2 \theta$ law is approximately 1 : 1; at a proton energy of 660 Mev this ratio becomes 8 : 1.

In conclusion the authors wish to express their gratitude to A. N. Sinaev for assistance in operating the apparatus and to L. A. Kuliukin for help in carrying out the calculations.

¹ Kozodaev, Tiapkin, Markov and Baiukov, Report of the Institute for Nuclear Problems, Acad. of Sciences USSR (1952).

² Kozodaev, Tiapkin, Baiukov, Markov and Prokoshkin, *Izv. Akad. Nauk SSSR, Ser. Fiz* **19**, 589 (1955).

³ W. E. Crandall and B. J. Moyer, *Phys. Rev.* **92**, 749 (1953).

⁴ Tiapkin, Kozodaev and Prokoshkin, *Dokl. Akad. Nauk SSSR* **100**, 689 (1955).

⁵ Baiukov, Kozodaev and Tiapkin, Report of the Institute for Nuclear Problems, Acad. of Sciences USSR (1954).

⁶ Iu. D. Prokoshkin and A. A. Tiapkin, *J. Exptl. Theoret. Phys. (U.S.S.R.)* this issue, p. 618.

⁷ Iu. D. Prokoshkin and A. A. Tiapkin, *J. Exptl. Theoret. Phys. (U.S.S.R.)* **33**, (in press).

⁸ R. H. Hildebrand, *Phys. Rev.* **89**, 1090 (1953).

⁹ R. A. Schuler, *Phys. Rev.* **96**, 734 (1954).

¹⁰ K. M. Watson and K. A. Brueckner, *Phys. Rev.* **83**, 1 (1951).